

## Video IF amplifier for multistandard TV receiver and VTR appliances

**Technology:** Bipolar

### Features

- Standard B/G-L suitable, processes negatively and positively modulated IF-signals with equal polarity of the output signal
- Ultra white inverter and ultrablack limiter for reducing transmission interference
- Internally noise protected gain control, no flyback pulses required
- Expanded video frequency response allows the demodulation of amplitude modulated MAC signals
- High input sensitivity
- Minimal intermodulation distortions
- Small differential error
- Fast AGC by controlled discharge of the AGC capacitor
- Standard L mode: AGC acting on peak white level, capacitor discharge control by averaged video signal
- Standard B/G: AGC acting on the sync. pulse peak
- Constant input impedance
- Video output voltage with narrow tolerance
- Video input/output for insertion of external sound trap
- VTR input/output with video switch
- Adjustable, delayed AGC for the tuner
- ESD protected

**Case:** 18-pin dual inline plastic

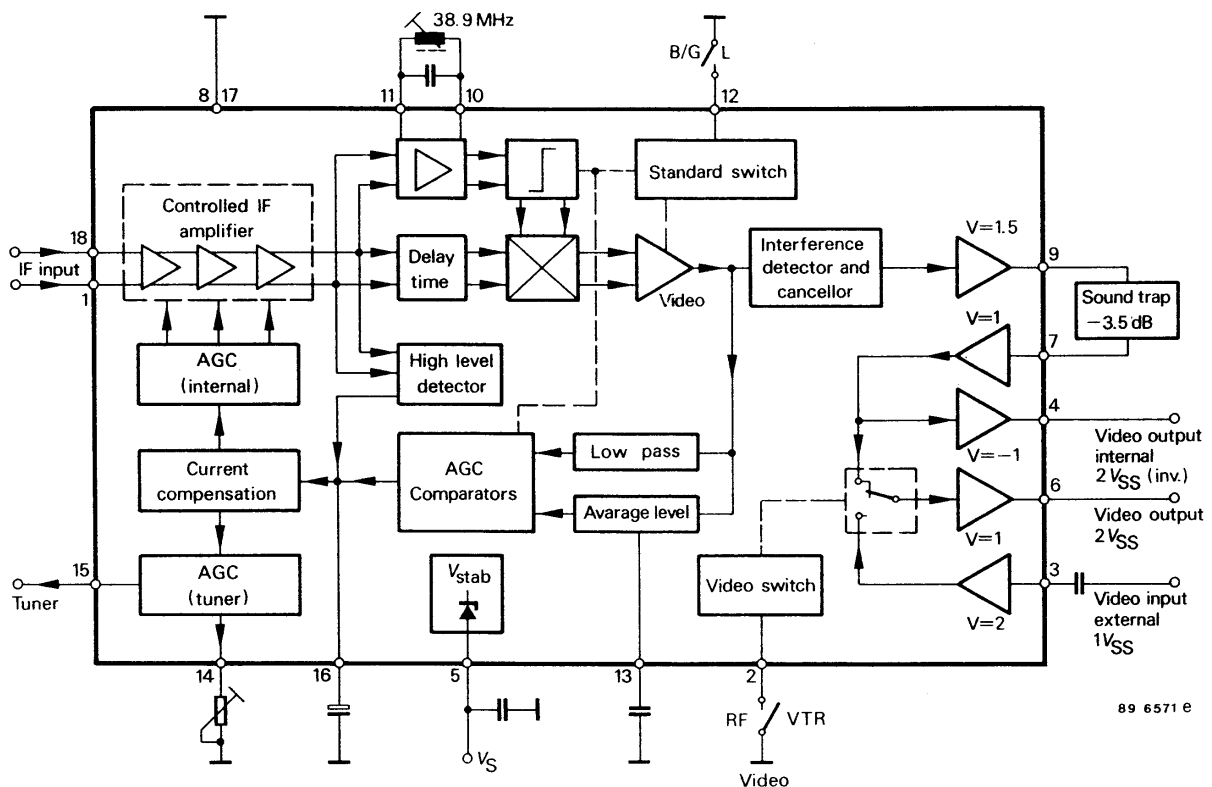

Figure 1 Block diagram

## Pin Configuration

Pin	Symbol	Function
1,18		IF input
2		Video switch control
3		VTR input, 1 V <sub>PP</sub>
4		VTR output, 2 V <sub>PP</sub> (inverted)
5		Supply voltage V <sub>S</sub>
6		Output video, 2 V <sub>PP</sub>
7		Video input, after sound trap, 2 V <sub>PP</sub>

Pin	Symbol	Function
8,17		Ground
9		Video output, 3 V <sub>PP</sub> from de- modulator
10,11		Demodulator circuit
12		standard switch B/G-L
13		Average capacitor standard L
14		Tuner AGC take over
15		AGC (tuner control)
16		IF AGC storage capacitor

## Circuit Description

The following functional units are integrated in this circuit combination for processing multi standard television IF signals:

The IF signal is supplied to the synchronous demodulator via a three-stage gain controlled wideband amplifier. A level detector limits the output voltage of the wideband amplifier in the event of overdrive.

The required switching carrier for the demodulator is obtained from the IF signal of the wideband amplifier by means of a selection and limiter stage. A delay network is connected upstream of the demodulator in order to compensate phase differences.

The polarity of the switching carrier at the output of the limiter stage can be reversed with the standard switch (Pin 12), with the result that negatively or positively modulated IF signals appear at the demodulator output with the same polarity. The demodulated video signal is filtered and amplified and is supplied to the video output (Pin 9) via a noise limiter stage.

The standard switch also adapts the operating point of the video post-amplifier and the IF AGC to the standard which is to be processed. In the case of standard B/G, the synchronous peak value acts as the control criterion for rapid charging and discharge. In contrast, rapid control is achieved for standard L by charging for ultra white and discharge by the average (Pin 13) with controlled reference.

An adjustable control current output (Pin 15) is available for delayed control of the tuner pre-stage.

A video source switch with 2 inputs is integrated for VTR applications. The external VTR signal is supplied capacitively to the input Pin 3 and is clamped to the synchronous peak value. The second video input Pin 7 is connected with Pin 9 (video signal from demodulator) via an external sound trap.

The sound trap must possess an attenuation for DC and AC of 3.5 dB so that the video switch is not overdriven. In addition, the demodulated video signal is available in inverted form as a VTR output signal at Pin 4, independent of the position of the video switch.

## Absolute Maximum Ratings

Reference point Pin 8, unless otherwise specified

Parameters	Symbol	Value	Unit
Supply voltage range Pin 5	$V_S$	10 to 13.5	V
External voltage Pin 2, 4, 12, 15	$V_{2,4,12,15}$	$V_S$	V
Pin 9, 16	$V_{9,16}$	8	V
Pin 6	$V_6$	6	V
Video output current,max load Pin 4, 6, 9	$I_0$	5	mA
Short circuit max 1 s Pin 4, 6, 9	$I_0$	30	mA
Junction temperature	$T_j$	125	°C
Ambient temperature range	$T_{amb}$	-25 to +70	°C
Storage temperature range	$T_{stg}$	-25 to +125	°C

## Thermal Resistance

Parameters	Symbol	Maximum	Unit
Junction ambient in soldered position	$R_{thJA}$	60	K/W

## Electrical Characteristics

$V_S = +12$  V,  $T_{amb} = +25$ °C, reference point Pin 8, unless otherwise specified

Parameters	Test Conditions / Pins	Symbol	Min.	Typ.	Max.	Unit
Supply voltage	Pin 5	$V_S$	10		13.5	V
Supply current	Pin 5	$I_S$	38	44	52	mA
<b>IF amplifier and AGC, pins 1 – 18</b>						
Min. input voltage		$V_i$		70	100	μV
Max. input voltage		$V_i$	100	120		mV
IF AGC gain reduction		$\Delta v_p$	60	65		dB
Input impedance		$R_i$ $C_i$		1.2 2		kΩ pF
Response time of the peak white control in standard L <sup>1)</sup>	Pin 16	$t_r$	10			μs
Available tuner AGC	Pin 15	$I_{15}$		5		mA
Automatic tuner AGC with IF control		AGC		61		dB
<b>Demodulator and output stage <sup>2)</sup>, pin 9</b>						
Ultra white level at standard B/G		$V_o$	7.1	7.5	7.9	V
Ultra black clamping level at standard B/G		$V_o$	4.0	4.2	4.4	V
Composite video output signal B/G <sup>3)</sup>		$v_{o(pp)}$	2.7	3.0	3.3	V

Notes:

- 1) A peak white value for at least 10 μs must be transmitted for each complete frame
- 2) All measurements Pin 9 without load
- 3) Residual carrier 10 %

Parameters	Test Conditions / Pins	Symbol	Min.	Typ.	Max.	Unit
Ultra black level at standard L		$V_0$	3.8	4.0	4.2	V
White level at standard L		$V_0$	6.8	7.2	7.6	V
Video signal standard L <sup>4)</sup>		$v_{0(pp)}$	1.85	2.1	2.35	V
Output DC current	$V_9 = 8\text{ V}$	$I_9$		2.5		mA
Difference of the video signals, standards L and B/G		$\Delta$			10	%
Upsetting factor sync. pulse				3		%
Tild between black and white				5	10	%
Clamping level of black limiter		$V_9$	250 mV below sync. (typ)			
Threshold of the ultra white inverter		$V_9$	900 mV above ultra white level (typ)			
Grey level of the ultra white inverter				5.9		V
Video bandwidth (-3 dB)		$B_{\text{video}}$	8.5	10		MHz
Video frequency response over the AGC range		$\Delta V_{\text{video}}$			2.0	dB
Differential gain error		$d$		3		%
Differential phase error				3		degree
Sound-chroma beat	(1.07 MHz intermodulation) relating to demodulated auxiliary colour carrier (Figure 3) video carrier = 0 db video carrier = -6 db video carrier = -24 db	$\alpha_{\text{IM}}$	52			dB
IF residual voltage at the video output	$f = 38.9\text{ MHz}$ $f = 77.8\text{ MHz}$	$v$ $v$		15 10		mV mV
<b>Standard switch, pin 12</b>						
Control voltage standard B/G		$V_{12}$	2.4		$V_S$	V
Control voltage standard L (Pin 12 not connected; standard B/G)		$V_{12}$	0		1.9	V
<b>Video switch</b>						
Control voltage for RF operation	Pin 2	$V_2$			1.9	V
Control voltage for VTR operation (Pin 2 not connected; VTR operation)	Pin 2	$V_2$	2.4		$V_S$	V
Clamp level	Pin 3 Pin 7	$V_3$ $v_7$		1.4 2.5		V V
Composite video output voltage	1 $V_{pp}$ at Pin 3 resp. 2 $V_{pp}$ at Pin 7 Pin 6	$v_{6(pp)}$		2.0		V

Note: <sup>4)</sup> Blanking level 30 % carrier amplitude

Parameters	Test Conditions / Pins	Symbol	Min.	Typ.	Max.	Unit
Sync. pulse level	Pin 6	$V_6$		2.0		V
Video switch bandwidth	Pin 6	B		10		MHz
Output DC current	$V_6 = 5\text{ V}$ Pin 6	$I_6$		2.0		mA
Cross talk	$v_3 = 1\text{ V}$ Pin 6 50 Hz to 10 MHz sin $v_{1-18} = 0\text{ V}$ , $V_2 = 0\text{ V}$ , $V_{16} = 4\text{ V}$			55		dB

**VTR output, pin 4**

Composite video output (inverted)	$V_7 = 2\text{ V}_{pp}$ (peak to peak)	$v_{4(pp)}$		2.0		V
Sync. pulse level		$V_4$		$V_S - 2.6$		V
Output DC current	$V_4 = 10\text{ V}$	$I_4$		2.0		mA

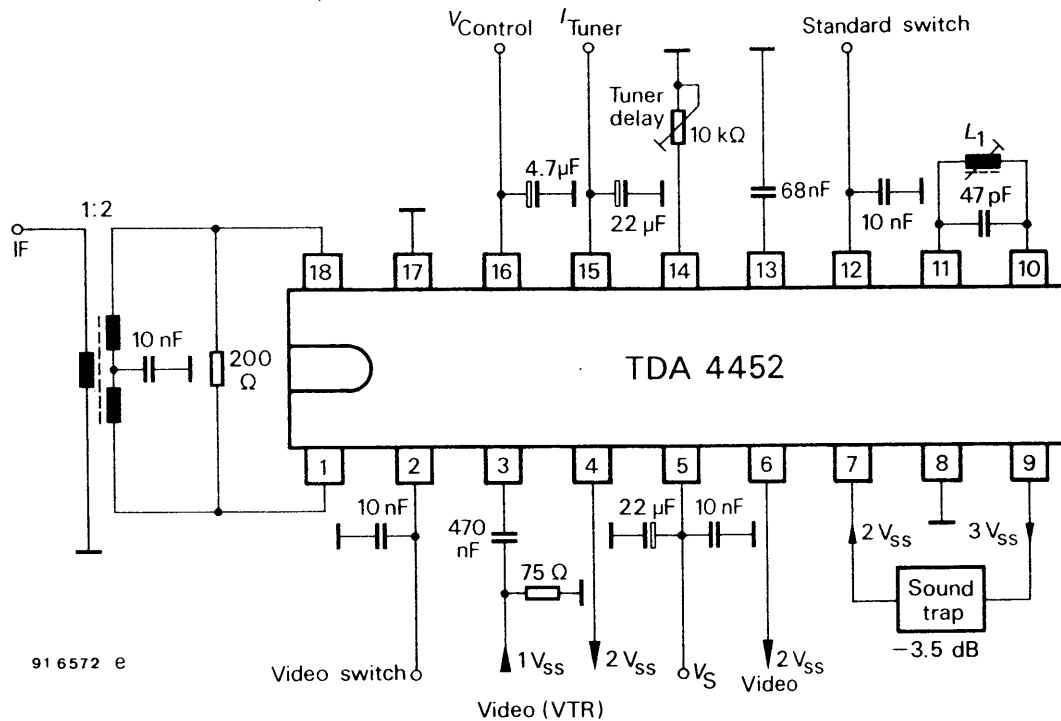

Figure 3 Test circuit

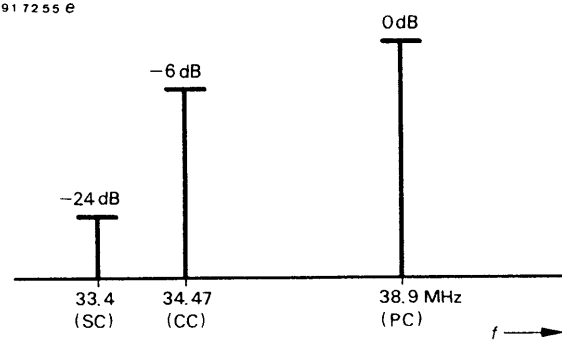
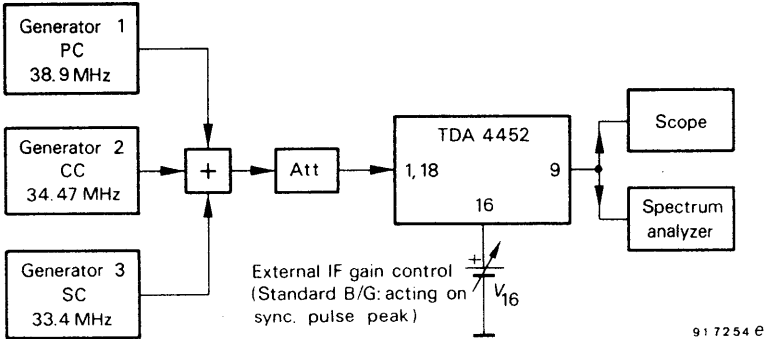

Figure 2 Test of intermodulation

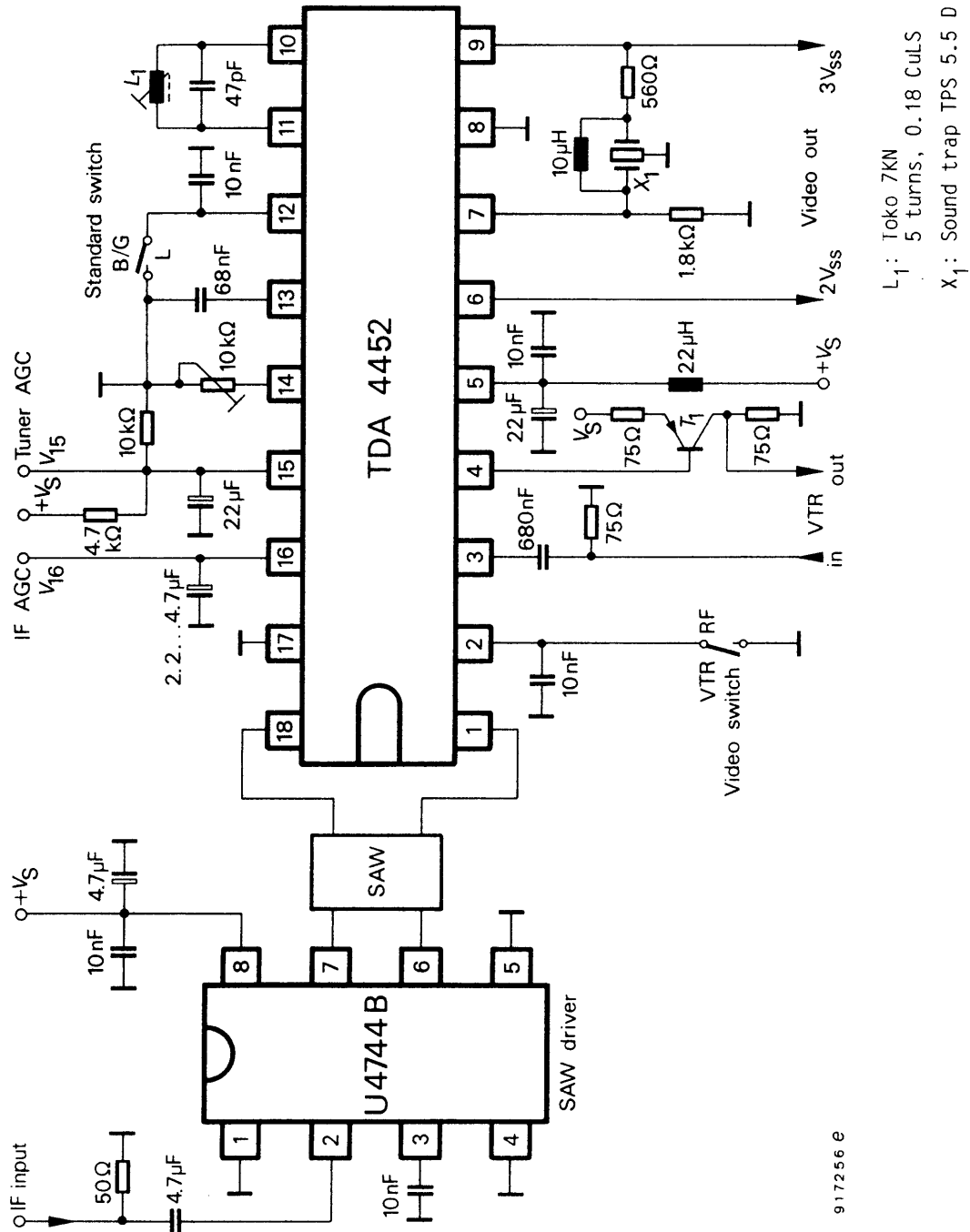
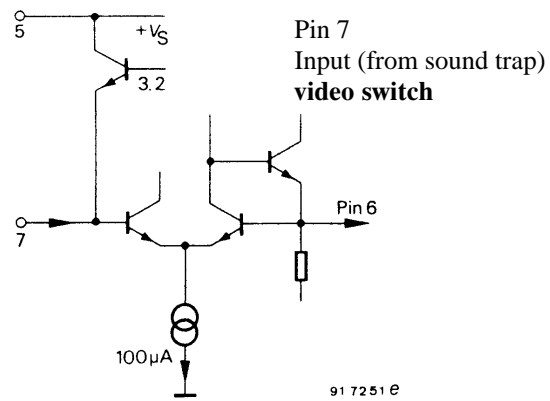
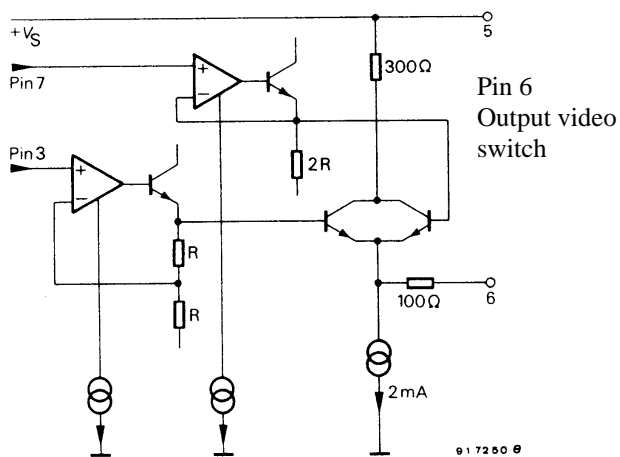
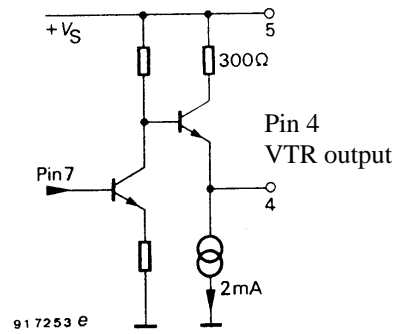
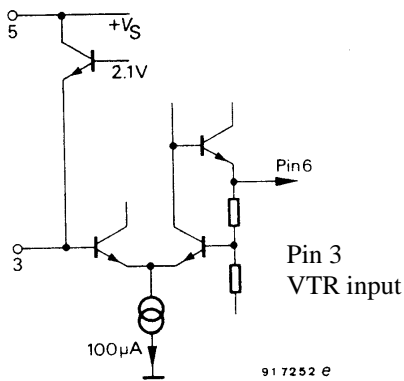
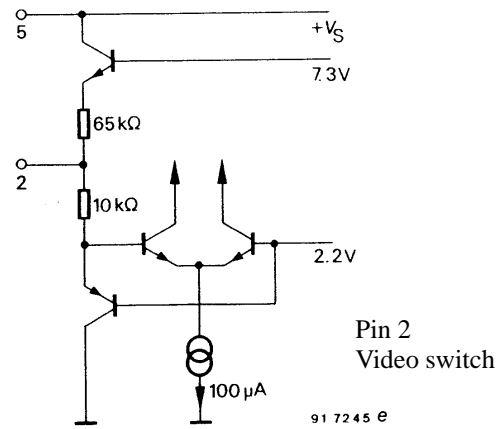
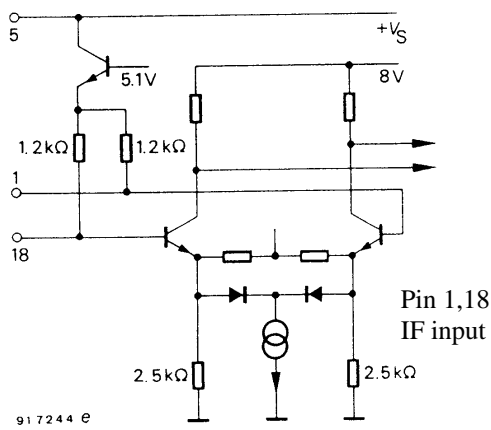
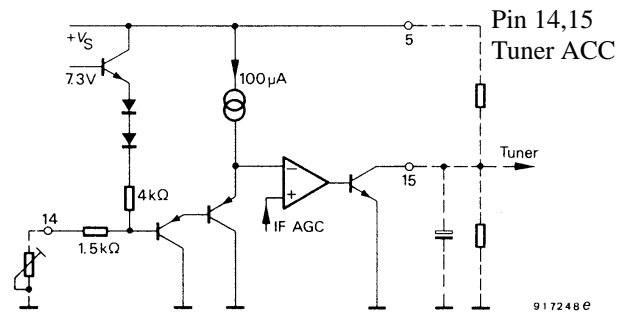
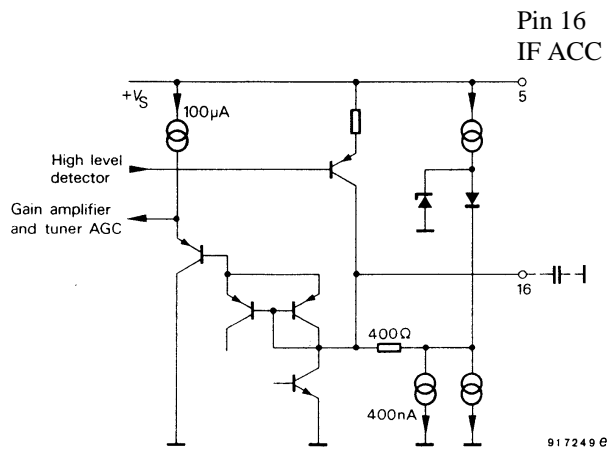
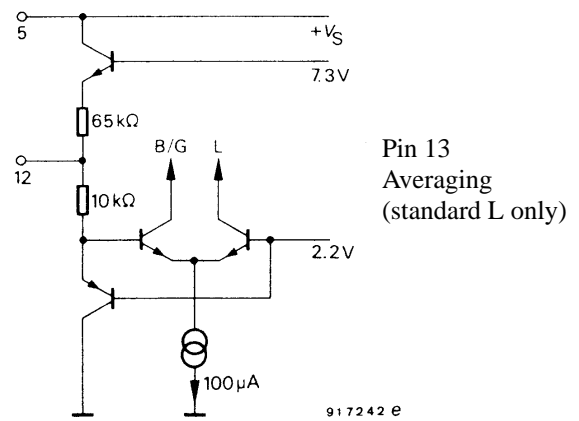
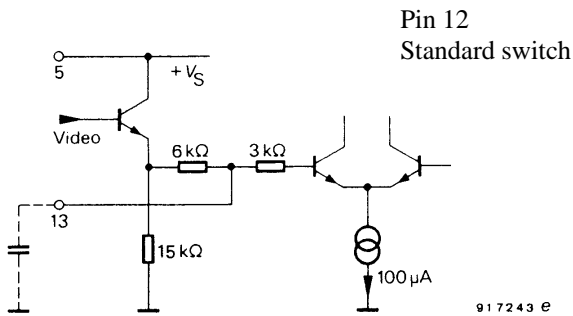
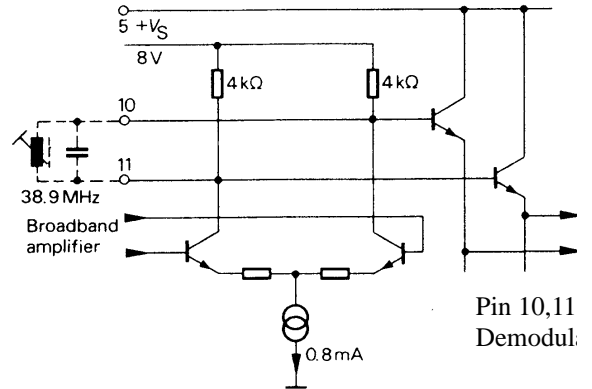
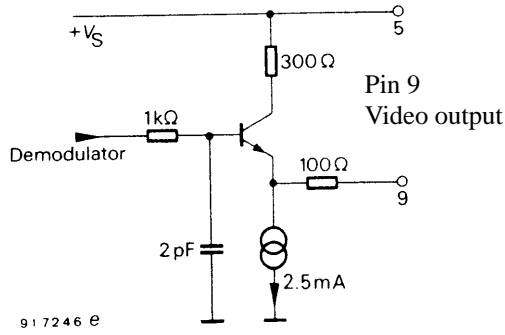

Figure 4 Application circuit

## TDA 4452







### Dimensions in mm

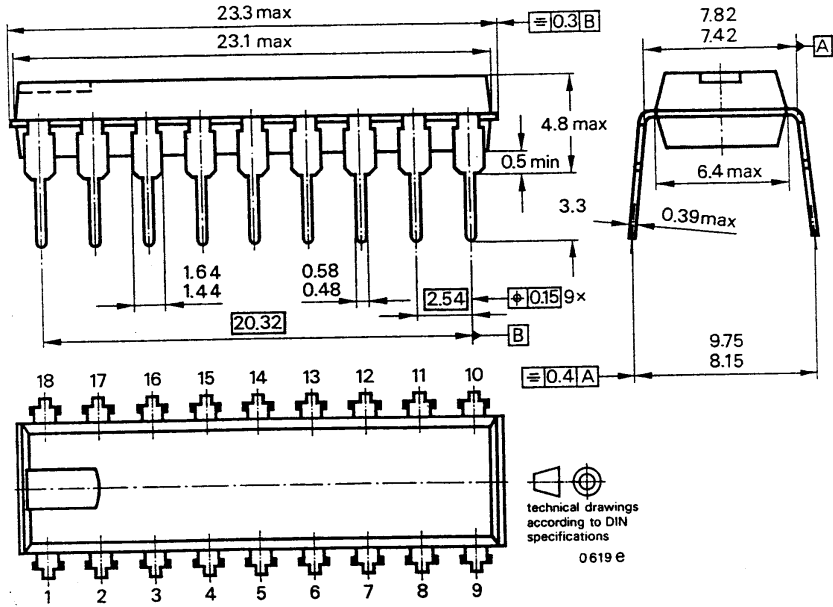

## OZONE DEPLETING SUBSTANCES POLICY STATEMENT

It is the policy of **TEMIC TELEFUNKEN microelectronic GmbH** to

1. Meet all present and future national and international statutory requirements and
2. Regularly and continuously improve the performance of our products, processes, distribution and operating systems with respect to their impact on the health and safety of our employees and the public, as well as their impact on the environment.

Of particular concern is the control or elimination of releases into the atmosphere of those substances which are known as ozone depleting substances (ODSs).

The Montreal Protocol (1987) and its London Amendments (1990) will soon severely restrict the use of ODSs and forbid their use within the next ten years. Various national and international initiatives are pressing for an earlier ban on these substances.

**TEMIC TELEFUNKEN microelectronic GmbH** semiconductor division has been able to use its policy of continuous improvements to eliminate the use of any ODSs listed in the following documents.

1. Annex A, B and list of transitional substances of the Montreal Protocol and the London Amendments respectively
2. Class I and II ozone depleting substances in the Clean Air Act Amendments of 1990 by the Environmental Protection Agency (EPA) in the USA and
3. Council Decision 88/540/EEC and 91/690/EEC Annex A, B and C (transitional substances) respectively.

**TEMIC** can certify that our semiconductors are not manufactured with and do not contain ozone depleting substances.

**We reserve the right to make changes to improve technical design without further notice.**

Parameters can vary in different applications. All operating parameters must be validated for each customer application by the customer. Should the buyer use TEMIC products for any unintended or unauthorized application, the buyer shall indemnify TEMIC against all claims, costs, damages, and expenses, arising out of, directly or indirectly, any claim of personal damage, injury or death associated with such unintended or unauthorized use.

TEMIC TELEFUNKEN microelectronic GmbH, P.O.B. 3535, D-74025 Heilbronn, Germany  
Telephone: 49 (0)7131 67 2831, Fax Number: 49 (0)7131 67 2423